

## ATP Price Computing Scales

### General Specifications

- |                   |   |
|-------------------|---|
| • Display         | 20mm digit LCD display, with white LED backlight                          |
| • Capacities      | 3kg~30kg  |
| • Pan size        | 230 x 300mm   |
| • Keyboard        | 20 keys (Membrane keyboard)   |
| • Housing         | ABS plastic   |
| • Max. Divisions  | 3,000; 2 x 3,000e; 6,000d   |
| • ADC update      | ≤ 1/10 second   |
| • Operating Temp. | -10°C~+40°C   |
| • Power           | AC adapter (12V/500mA), rechargeable battery (6V/4Ah)                     |
| • Gross weight    | 5kg   |
| • Packing         | Master carton 4 in 1, gross weight 23.5kg, dimension 0.162 m <sup>3</sup> |



- Capacities from 3kg to 30kg
- Applications: 1. Weighing unit conversion 2. Change 3. PLUs
- OIML approval from NMI (approval no.T7305)
- Battery provides up to 70 hours of continuous use (without backlight)
- Stainless steel pan
- Optional fruit pan
- Optional RS232 to connect to computer or printer
- Optional initial-verification



## ATP Price Computing Scales

Model Name	Capacity	Readability	Division	Approx. weight	Approval
ATP-3K	3kg	0.5g	6,000d	5kg	CE
ATP-6K	6kg	1g	6,000d	5kg	CE
ATP-15K	15kg	2g	6,000d	5kg	CE
ATP-30K	30kg	5g	6,000d	5kg	CE
ATP-3K-M	3kg	1g	3,000e	5kg	CE, OIML
ATP-6K-M	6kg	2g	3,000e	5kg	CE, OIML
ATP-15K-M	15kg	5g	3,000e	5kg	CE, OIML
ATP-30K-M	30kg	10g	3,000e	5kg	CE, OIML
ATP-6K-MR	6kg	1g/2g	2 x 3,000e	5kg	CE, OIML
ATP-15K-MR	15kg	2g/5g	2 x 3,000e	5kg	CE, OIML
ATP-30K-MR	30kg	5g/10g	2 x 3,000e	5kg	CE, OIML

### Options



### Dimensions(mm)

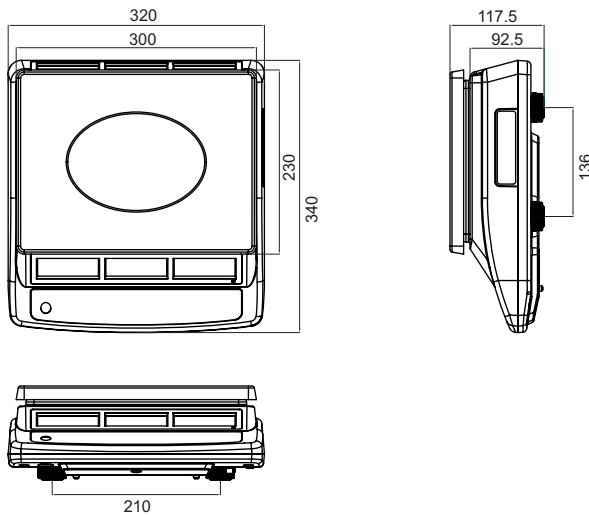

### Print formats

Net: 2.000KG  
 Unit price  
 EUR 5.00/KG  
 Price:  
 EUR 10.00  
 Total:  
 EUR 16.00