

## QHW Weighing Scales

### General Specifications

- Display 24mm digit LCD display, with white LED backlight
- Capacities 3kg~30kg
- Platform size 230 x 300mm
- Keyboard 7 keys (Membrane keyboard)
- Housing ABS plastic
- Max. Divisions 3,000e; 2 x 3,000e; 30,000d; 60,000d
- ADC Sigma delta
- ADC update  $\leq 1/10$  second
- Operating Temp.  $-10^{\circ}\text{C} \sim +40^{\circ}\text{C}$
- Power AC adapter (12V/500mA), internal rechargeable battery (6V/4Ah)
- Gross weight 5.1kg
- Packing Master carton holds 4, gross weight 23kg, dimension 0.188m<sup>3</sup>



- Applications: 1. Check weighing 2. Counting 3. Percentage 4. Accumulation 5. Weighing unit conversion
- Check weighing (user can set hi/low limit for weighing, counting and percentage)
- OIML approval from NMI (approval no.T7305)
- Battery provides up to 70 hours of continuous use (without backlight)
- Optional RS-232 to connect to computer, LP-50 label printer or TPuP mini printer and ECR
- Optional rear display
- Optional initial-verification



## QHW Weighing Scales

Model Name	Capacity	Readability	Division	Approx. weight	Approval
QHW-3K	3kg	0.1g	30,000d	5.1kg	CE
QHW-6K	6kg	0.2g	30,000d	5.1kg	CE
QHW-15K	15kg	0.5g	30,000d	5.1kg	CE
QHW-30K	30kg	1g	30,000d	5.1kg	CE
QHW+-3K	3kg	0.05g	60,000d	5.1kg	CE
QHW+-6K	6kg	0.1g	60,000d	5.1kg	CE
QHW+-15K	15kg	0.2g	60,000d	5.1kg	CE
QHW+-30K	30kg	0.5g	60,000d	5.1kg	CE
QHW-3K-M	3kg	1g	3,000e	5.1kg	CE, OIML
QHW-6K-M	6kg	2g	3,000e	5.1kg	CE, OIML
QHW-15K-M	15kg	5g	3,000e	5.1kg	CE, OIML
QHW-30K-M	30kg	10g	3,000e	5.1kg	CE, OIML
QHW-6K-MR	6kg	1g/2g	2 x 3,000e	5.1kg	CE, OIML
QHW-15K-MR	15kg	2g/5g	2 x 3,000e	5.1kg	CE, OIML
QHW-30K-MR	30kg	5g/10g	2 x 3,000e	5.1kg	CE, OIML

### Options



### Dimensions(mm)

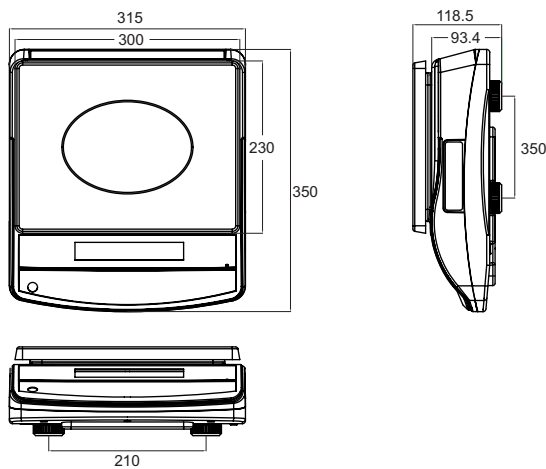

### Print formats

2012/03/07	15:04
PERCENT:	100.00 %
2012/03/07	15:05
TOTAL NO.	2
TOTAL WT.	19.996kg
2012/03/07	15:04
WEIGHT:	10.800 kg
UNIT WT:	49.989 g
QUANTITY:	216 PCS
2012/03/07	15:04
S/NO:	2
GROSS:	9.998kg
TARE:	0.000kg
NET:	9.998kg