

SW-II-M Weighing Scales



Features:

- 25mm LCD display (LED backlight)
- Capacities from 3kg to 30kg
- 3 mechanical switch keys
- Select weighing unit (kg/g)
- Rechargeable battery
- Battery provides up to 70 hours of continuous use (without backlight)

Options:

- 15mm rear display

Specification:

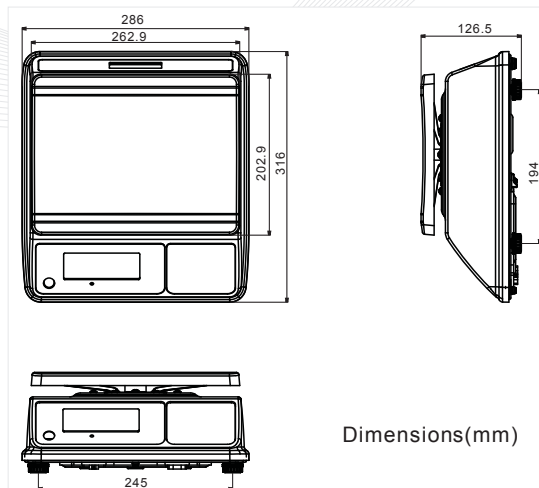

Dimensions(mm)

| Model | SW-II-M | | | | SW-II-MR | | |
|----------------|------------------------------------------------------------------|-----|------|------|------------|------|-------|
| Display | 25mm LCD display (LED backlight) | | | | | | |
| Capacity | 3kg | 6kg | 15kg | 30kg | 6kg | 15kg | 30kg |
| Readability | 1g | 2g | 5g | 10g | 1/2g | 2/5g | 5/10g |
| Max. Divisions | 3,000e | | | | 2 x 3,000e | | |
| Keyboard | 3 mechanical switch keys | | | | | | |
| Housing | ABS plastic | | | | | | |
| Pan size | 200mm x 260mm | | | | | | |
| ADC | Sigma delta | | | | | | |
| ADC update | ≤1/10 second | | | | | | |
| Operate. Temp. | -10°C~+40°C | | | | | | |
| Power | AC adapter (12V/500mA), internal rechargeable battery (6V/3.2Ah) | | | | | | |
| Gross weight | 2.78kg | | | | | | |
| Packing | Master carton 4 in 1, dimension 0.118 m ³ | | | | | | |